

Artikel-Nr.: X39.2A1-1620_4

Zolltarifnummer: 84819000

EAN: 4067025072890

Shop-URL: https://armag.de/X39.2A1-1620_4

Gewicht: 0.024 kg

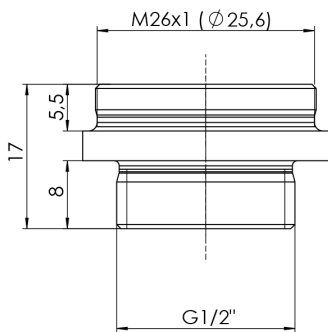

[Gewindenippel M26 x 1/2" - SW 15 mm innen \(AG x AG\)](#)