

**Artikel-Nr.:** X59.5A1-1370\_2

**Zolltarifnummer:** 84819000

**EAN:** 4067025132518

**Shop-URL:** [https://armag.de/X59.5A1-1370\\_2](https://armag.de/X59.5A1-1370_2)

**Gewicht:** 0.031 kg

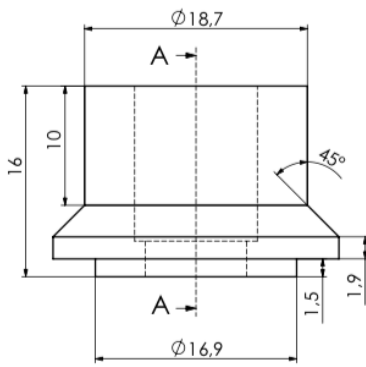

SCHNITT A-A

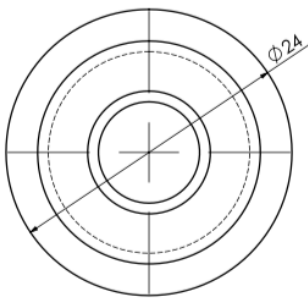
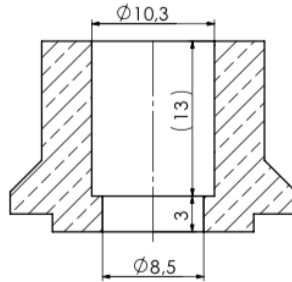

**Längenausgleichshülse Messing 10,3 x 16**