

Artikel-Nr.: X59.5A1-1522_1

Zolltarifnummer: 84819000

EAN: 4067025132563

Shop-URL: https://armag.de/X59.5A1-1522_1

Gewicht: 0.004 kg

SCHNITT A-A

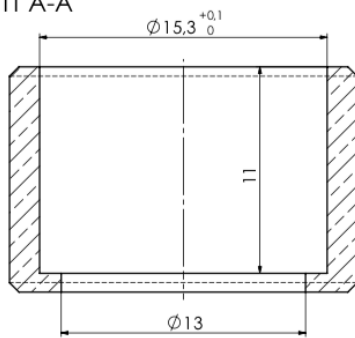

[Längenausgleichshülse Messing 15,3 x 12](#)